

What's new in NX 8.5

Smarter decisions. Better products.

Benefits

- More productive product development
- Better product quality, faster development, lower costs
- Faster, more efficient modeling
- Better compliance with standards and product requirements
- More clearly understand finite element model context
- Faster design-analysis iterations
- Improve product durability
- Speed simulation time up to 25 percent
- Faster NC programming and machining of parts
- Save on cutting tool costs
- Better part accuracy

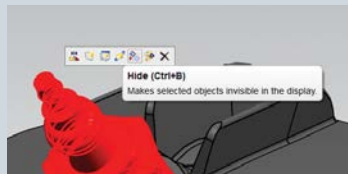

Context-sensitive toolbars show you only what you need.

Summary

NX™ 8.5 software delivers new capabilities and many customer-driven enhancements to existing features. These improvements reduce the time it takes to create, analyze, exchange and annotate your data. NX 8.5 introduces new simulation capabilities that add new optimization and multiphysics solutions, help you prepare and update more accurate analysis models faster, and speed solution time for structural, thermal and flow analysis by as much as 25 percent. Boost your part manufacturing productivity with new capabilities that accelerate NC programming and machining times, close the quality inspection loop, manage tooling libraries and connect the NC work package directly to the shop floor.

NX 8.5 for design productivity

Fundamentals

The NX 8.5 user interface provides you with as many or as few options as you need. See-through preview highlights the feature being created or modified by de-emphasizing other geometry. New options for the display of smooth edges make it easier to understand your model, and model rotation is easier to use and more intuitive. Enhanced measurement options make it easier to investigate a model and determine clearances.

New context-sensitive toolbars show you the options you need for the situation you are in and can be fully customized. This means less time hunting for the command you need.

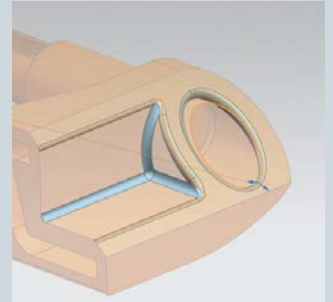

See-through preview makes it easier to see your geometry change.

NX

Answers for industry.

SIEMENS

What's new in NX 8.5

Sketching

Sketching in NX 8.5 has been streamlined. The coordinate system display in sketches has been simplified to make it clearer, and sketch coordinate systems now have unique names to make them easier to select. You also have increased flexibility when placing constraints, streamlining the sketching process and reducing development time.

Feature-based modeling

NX 8.5 delivers many usability enhancements and new capabilities in feature-based modeling. You can use open profiles to create features, which automatically extend to the surrounding geometry to create a closed feature. You can now emboss a body with another body, which is useful for creating dies or ensuring sufficient clearance between two parts.

There is a new way to create unions between two solid or sheet bodies. You can select which regions you want to keep or remove, allowing you to create your desired geometry with about 30 percent fewer commands and 25 percent fewer features.

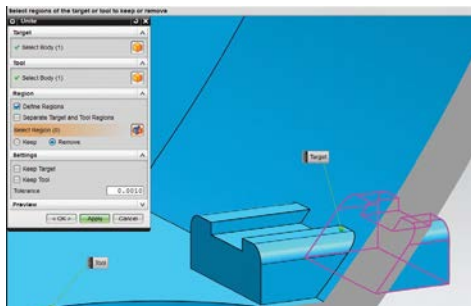

You can select which part of a body you want to keep.

Creating helical shapes such as springs or threads has been streamlined with new commands which give you full control over the properties of the helix. The resulting shapes are fully parametric and easier to modify than in previous versions.

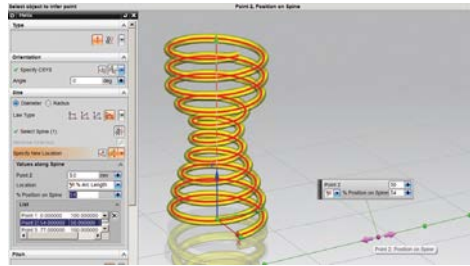

Helix creation is easier and more powerful.

You can now add draft to a model using an intersecting surface as the parting line. While this has been possible in the past, the new functionality makes this action significantly faster and more efficient, with 40 percent fewer features and only a third as many commands as the old method.

Synchronous modeling

NX 8.5 is the fifth release of NX with synchronous technology, and it continues to be enhanced and refined with new functionality. The existing commands are now more capable and more intuitive to use. You can now label faces as blends, adding intelligence to history-free data and making it easier to get the results you want when you use synchronous modeling to modify the geometry. New options give you greater control of your geometry as you modify it, meaning you are more likely to get the result you want the first time. Synchronous technology can now alert you when the changes you are attempting will cause potential errors so that you can adapt accordingly and spend less time repairing your data. The flexibility of

synchronous technology makes it easier to do "what if" design studies so you can explore all options and optimize your design.

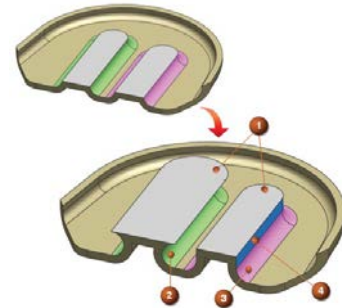

The face on the right has been labeled as a blend, the one on the left has not.

Freeform modeling

Freeform modeling in NX 8.5 has improved geometry creation, analysis and visualization features. Some commands have been enhanced with new law types, giving you more tools to create the complex geometry you need. You can enhance the visual display of your curve geometry by highlighting end points in several different ways. New surface and radius analysis tools help you ensure that your geometry meets all necessary requirements. You can now fit a curve or a surface to existing geometry such as facet bodies or points, which is useful for reverse engineering.

Data exchange

NX 8.5 builds on the open philosophy that guides Siemens PLM Software with tools to work seamlessly with other systems, protecting your design investment. With the improved JT™ Export interface, it's easier to control how your information is exported. You can save your configuration to a file, saving time on future jobs. NX

now reads more data from JT files, making the resulting NX file easier to understand and diagnose, which means you spend more time using your data and less time trying to decipher it. A new wizard makes it easier to export data to the DXF or DWG formats by streamlining the process and improving control over export options with an improved user interface.

Routed systems design

Routing in NX 8.5 makes it faster and easier to create the geometry you need. New capabilities allow you to mirror routing objects to create symmetric routing networks, saving time and ensuring consistency. There are new options for creating and navigating runs which make it easier and faster to ensure compliance. It's easier to find and replace components with the same specifications, saving time and ensuring that requirements are met.

Sheet metal design

Sheet metal design has been thoroughly enhanced in NX 8.5. You can now create dimple features before or after bends, or put bends across existing features, and everything adapts correctly. NX pattern feature functionality has been extended to sheet metal in 8.5, saving time when creating multiple features. You now have more options to help you create bend regions, making it easier to create compliant geometry in fewer steps. There is now a wizard with cleanup and conversion options to help you convert a

solid model into a sheet metal part. With this and other tools you can quickly generate a robust, re-usable sheet metal part from a standard solid model, reducing design time.

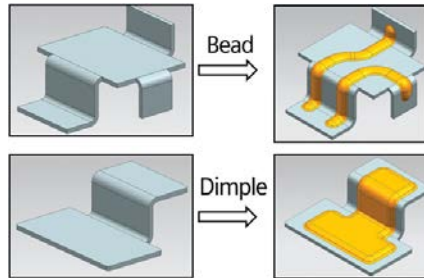

Beads and dimples can now be added after bends.

Re-use

The NX Reuse Library, a common repository for all of your re-usable geometry, has been enhanced for NX 8.5. You now have the option of changing deformable parameters on a part when you drag it from the Reuse Library, giving you more control. When you add a component to an assembly, you now have the option of viewing the component in a preview window to verify that it meets your needs before you place it. You also have the option to add multiple occurrences of a component at the same time. This is especially efficient for standard parts that are used in many places at once, like fasteners.

Validation

Check-Mate has been enhanced with new checkers that make it easier to investigate your data and find issues before they cause problems down the road. This makes you more productive and ensures quality models.

Visualization

NX 8.5 delivers improved visualization tools that make it easier to understand your models and generate aesthetically correct renderings of them. A new background environment maps a panoramic image onto a hemispherical dome, so as you pan around your model, it appears to be in realistic environment from any angle, making visualization more realistic and useful.



Visualization tools enable you to make attractive, realistic images.

NX 8.5 for tooling design productivity

Tooling design in NX 8.5 has been enhanced to optimize the overall mold and die design process and to improve productivity by eliminating many manual modeling steps.

Mold design

Parting surface design methodologies have been improved to make the design process more efficient. Creating and modifying cooling channels is easier and more intuitive. Injection flow analysis functions are now integrated into NX, permitting the

user to perform more flow analysis inside NX. The standard parts management tool has been improved to provide consistent user interaction by using the NX Reuse Library framework. Many new capabilities in the electrode design process have been introduced to improve user productivity.

Progressive die design

A variety of improvements have been made to support the more complex un-forming design workflows. Process support for parts with zero bend radius, bends with complex features such as Gusset, ribs, etc. are now possible. Improved engineering die design (transfer and compound dies) process supports many aspects of die design more efficiently.

Stamping die design

NX 8.5 delivers new capabilities to perform more accurate trim angle checks for complex parts. Support is also added for the complex draw die punch design process that eliminates many manual modeling processes. Plus new blank nesting capabilities perform the nesting operations in an integrated environment.

Drafting

Drafting in NX 8.5 has been comprehensively enhanced in response to customer input. You can now create lightweight drawing views which improve performance and reduce system resource usage. The drafting user interface has also been simplified to clean up the interface and make it easier to find the commands you need.

The view creation wizard has been enhanced with new commands and options designed to optimize performance with large assembly drawings. A new option gives you the ability to permanently align a view with other views, giving you greater control.

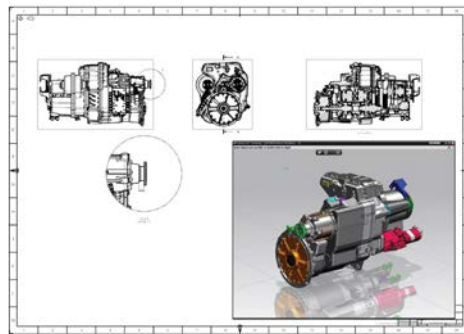

Lightweight views save system resources.

You now have the option of having your associative custom symbols update automatically when the master you created them from changes, helping ensure that your symbols remain up to date. New options give you greater control over the linking and positioning of custom symbols. You also have more control over

weld symbols, including the ability to change the weld standard without having to reset the whole drafting standard in your NX session. The new function lets you control the size of your weld symbols more easily. All of these changes are designed to make you work faster and smarter when creating standards-compliant drawings.

Product and manufacturing information

Product and manufacturing information (PMI), which embeds critical manufacturing and other information directly in your 3D geometry, has been enhanced for NX 8.5. The PMI user interface has been simplified and some commands have been renamed and moved to make them more intuitive to use. You now have greater control over which PMI is displayed in which places, helping to clean up and manage your PMI. When trying to find the PMI associated with selected geometry, you now have the choice of viewing it in a permanent or temporary view. When extracting geometry from a body, you now have the option of extracting PMI data along with it, reducing rework and helping create smarter models.

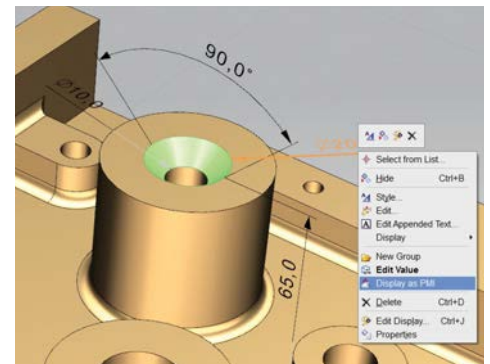

PMI is easier to understand and manage in NX 8.5.

NX DraftingPlus

NX DraftingPlus delivers enhanced 2D design capability inside NX, and on its third release, continues to add functionality. You can now create Drawing Booklets, which are multiple drawing files combined into a structure that allows you to group together the drawings needed to define an assembly or study. Since the files in the booklet are managed as a single unit, it's easier to manage them; and the impact on system resources is reduced, making the whole system faster.

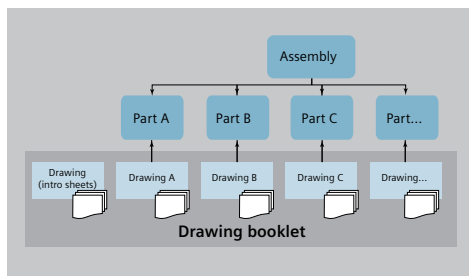

Drawing booklets help you organize your drawings.

It is now possible to easily move drawing objects from one view to another while maintaining their associativity and proper scale, orientation and style. You can now smash a drawing view, meaning the objects in that view are no longer associated with the view itself. This gives you more flexibility in placing your objects in a 2D design environment.

NX 8.5 for simulation productivity

Whether developing race car components for next week's race, or the structure for the next-generation submarine that will launch five years later, all development teams face time constraints that are costly when designs fail and schedules aren't met. NX for Simulation is a modern simulation environment that can help development teams engineer their products right the first time. With the 8.5 release, NX CAE introduces over 240 new capabilities in areas such as simulation modeling, structural, thermal, flow, motion, multiphysics and optimization analyses.

Simulation modeling

FE model in context NX CAE 8.5 expands upon its unique distributed CAE environment for building analysis model assemblies by allowing you to edit a single FE component model in the context of the overall assembly. In NX CAE 8.5, you can now set the work part independently of the displayed part, which allows you to see and reference the rest of the FE assembly while editing just the FE component model. In previous releases, if you wanted to generate a mesh or edit an existing mesh, you would first need to change the displayed part to the FEM file containing the geometry. So you would have only seen the FE component displayed on the screen, which could make it difficult to

understand where you might need to edit node locations for connections to the rest of the assembly.

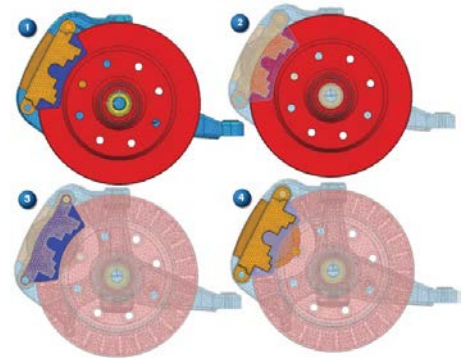

An assembly FEM of a disk brake assembly. 1: The assembly FEM is both the displayed and the work part. 2: The disk is the work part. 3: The brake pad is the work part. 4: The caliper is the work part.

The new FE model in context capability supports many new workflows, including the following:

- With an assembly FEM displayed, make a component FEM the work part to create or edit meshes, clean up or modify polygon geometry, or modify physical and material properties.
- With an assembly FEM displayed, make a subassembly FEM the work part to resolve label conflicts or edit connection meshes.

- With a simulation displayed, make the component FEM the work part to modify meshes or polygon geometry in the context of applied loads and boundary conditions.
- With a FEM displayed, make the idealized part the work part to create or modify geometry in the context of the mesh.

FE model in context significantly speeds the modeling process because each of these workflows help engineers make the right modeling decisions in the right context of the problem to be solved.

Faster FE model updates NX CAE 8.5 includes improvements that speed the overall update process for the FE model when the design changes. Specifically, these improvements are designed to minimize the amount of polygon geometry that is affected when there are changes to the underlying CAD geometry.

Now, during the polygon geometry update process:

- Fewer polygon faces are deleted and recreated.
- Manual modifications that you make to the polygon geometry are now preserved.
- Fewer mesh mating conditions and stitch edge recipes are recreated and replayed.
- Fewer meshes are deleted and recreated.

These changes speed the update process, reduce potential manual rework and can save you significant time when working with large models.

Mid-surface productivity enhancements

A number of enhancements have been made to the mid-surfacing capabilities in NX CAE 8.5. These changes can provide a better result on the first pass, and ultimately allow you to mid-surface your part up to five times faster. Some of the new enhancements to the mid-surface command include:

- The progressive pairing option uses a new “rolling ball” thickness calculation algorithm which provides more granular thickness information throughout a body. This new algorithm calculates more accurate thickness data for both constant and variable thickness parts. This results in more accurate face pairs and you spend less time editing the data after mid-surface generation.
- Automatic pairing now available for tangent-continuous parts helps you reduce manual work on surfaces that are tangent within a specified angle.

- A new ability to create face pairs based on the ratio of thickness to face size is particularly helpful for models with highly variable thickness values.

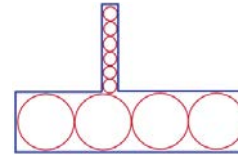

Illustration of “rolling ball” algorithm where the software uses the diameter of a ball at a given location as the thickness of the part at that location.

Solver-specific element quality checks

The element quality command now can evaluate the quality of elements in your model based upon the specific quality criteria employed by the solver you are using. This means NX CAE can highlight element quality issues before you export your input data file and run the solver, which saves you time and eliminates the frustration of finding quality issues at solve time. Solver-specific quality checks are supported for the following solver environments:

- NX Nastran®
- MSC Nastran
- Abaqus

- Ansys (Note: The Ansys solver-specific checks in NX are consistent with the quality checks in the standard Ansys solver. They are not consistent with the quality checks used by the Ansys Workbench platform.)
- LS-Dyna

Engineering optimization

NX Shape Optimization NX Shape Optimization is a new NX CAE product introduced in this release. NX Shape Optimization helps engineers suggest specific detailed improvements to an existing design when only minor changes and improvements are permitted due to design constraints. In these cases, engineers are typically looking to minimize stress concentrations, or to maximize selected natural frequencies, which are factors that can extend product life and durability. To achieve the objective, each design node is displaced with the objective of reducing the local stresses. In the high-stressed area, the design nodes are displaced outward and the structure grows; in the low-stressed area, the design nodes are displaced inward and the structure shrinks. The resulting node locations can be communicated to the design team in the form of an STL file, which allows designers to visually understand how to update the geometry.

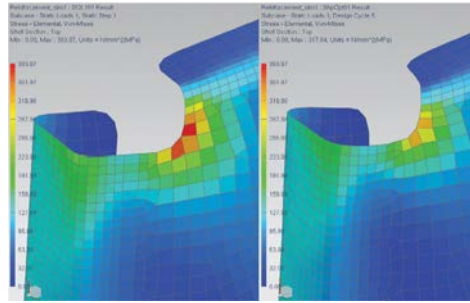

Left: Original design with high stress concentration. Right: New design after shape optimization.

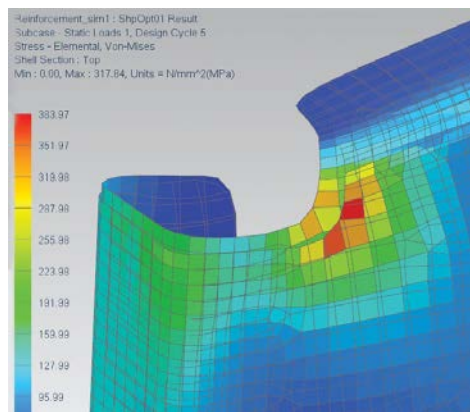

Overlay of new design and old design to show how dimensions have changed.

Geometry optimization in NX Thermal and NX Flow NX CAE 8.5 introduces geometry optimization within the NX Thermal and NX Flow products. Geometry optimization lets you drive the design toward an optimal solution by varying

design geometry and other parameters. This is useful for tradeoff studies and to determine optimum operating conditions for a product. For instance you may need to minimize the temperature of a critical component within an electronic device through variation of airflow patterns. One way to reduce the temperature may be to optimize the airflow rate into the device, which you can then set as the design variable. NX CAE will then automatically adjust the flowrate, update the model and solve, and evaluate the resulting temperature at the component. NX CAE then automatically iterates this process until the desired objective is achieved – leaving you with the optimal flowrate and temperature in a fraction of time it would take using conventional means.

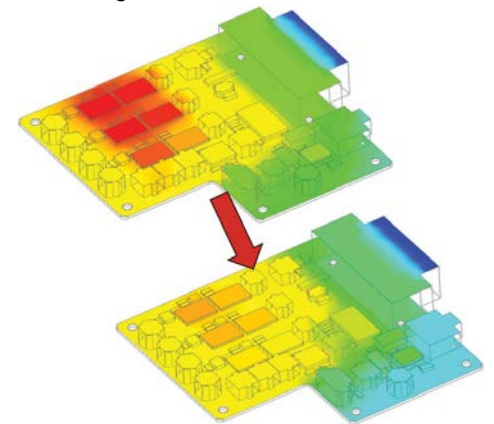

Minimizing critical component temperature by optimizing flowrate.

Structural analysis

Edge-to-edge glue and contact support for NX Nastran NX Nastran is a leader in structural analysis solutions and is at the forefront of developing new connection types that allow engineers to build their models faster. NX Nastran 8.5 introduces new glue and contact connections which are also supported within the NX CAE 8.5 release.

New edge-to-edge gluing is a simple and effective method to join dissimilar shell meshes. Glue connections, between the edges of shell elements in the same plane, simplify the modeling process for the engineer without compromising accuracy of the structural analysis.

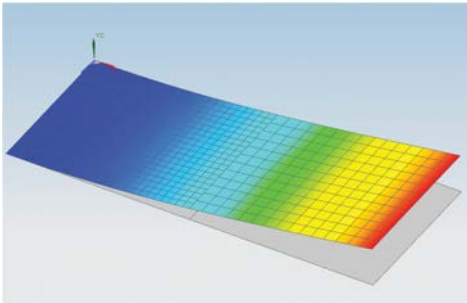

Edge-to-edge glue allows easy connection between two dissimilar shell meshes along an edge.

Similarly, NX CAE 8.5 supports the new edge-to-edge contact capabilities in NX Nastran 8.5 to define contact conditions between selected polygon or element

edges of axisymmetric elements. Edge-to-edge linear contact can be used in solutions for linear statics, normal modes, buckling and modal frequency and transient response.

Bolt preloads on solid elements for NX Nastran NX Nastran 8.5 adds a new capability supported by NX CAE 8.5 to allow more detailed representation of bolts, including contact between hole and bolt, which gives you more accurate results.

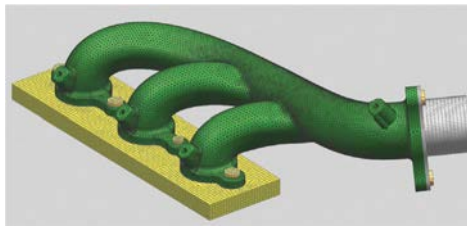

Model bolt preloading on solid elements such as for the bolts mounting this manifold assembly.

Import Fibersim HDF5 files in NX Laminate Composites Fibersim™ software is now a member of the Siemens PLM product family, and so NX CAE is able to strengthen its integration with Fibersim. In NX CAE 8.5, you can directly import Fibersim ply-based layups from a Fibersim HDF5 (*.h5) file into NX Laminate Composites. In previous releases, you could only import layups from a Fibersim XML file. Importing the HDF5 file gives you more information for each ply than is available in the XML file, such as:

- The starting point of the draping
- The direction of the draping
- The orientation angle

Thermal and flow analysis

Multithreading to achieve faster thermal computations Multithreading takes advantage of multicore and multi-processor hardware to speed up the thermal computations. The new multithreading option in NX Thermal is most useful for radiation-dominated models. For transient runs, depending on output intervals, run time can be reduced by up to about 25 percent (using 4 cores).

New fully coupled scheme for parallel flow solver NX CAE 8.5 introduces a fully coupled scheme for the parallel flow solver in NX Flow, which helps to solve large models faster. This fully coupled pressure-velocity scheme is now used by default and is better suited for solving steady-state models or transient models using larger timesteps. In the previous release, the fractional step scheme was the only scheme used by the parallel flow solver, but is more suitable for transient models with small timesteps.

Multiphysics

Durability analysis based on flexible body motion simulation results You can now easily perform a durability analysis on a component that was simulated as a flexible body in a motion analysis. In NX, you can seamlessly move from CAD assembly to a motion study using a flexible body, and then use the results of the

motion study to kick off a durability process on the component in question. Based on the durability results, you could even use the new NX Shape Optimization module introduced in this release to smooth out areas of concern in the geometry that would help extend product life.

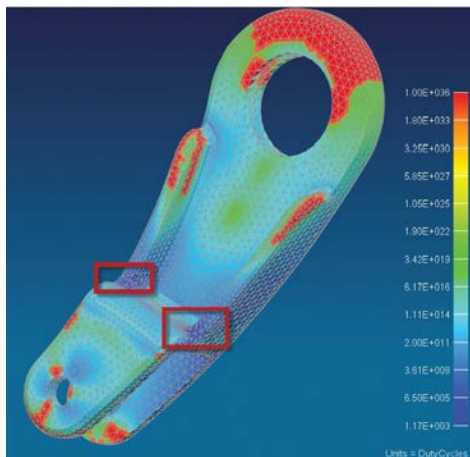
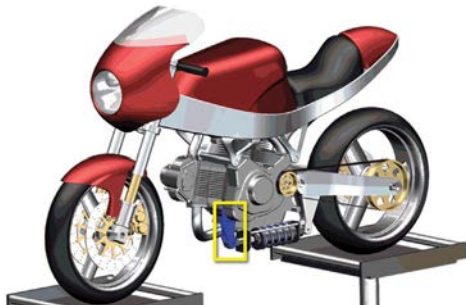

Durability results based on a flexible body motion simulation of motorcycle suspension bracket.

Motion analysis

Suppress/unsuppress motion objects

A new feature in NX Motion Simulation allows you to suppress individual motion objects and their dependent objects from being included in the active solution. For example, you can suppress a link to remove it from the solution. That link's dependent joints and any other dependent objects – such as springs, markers, bushings, etc. – will also be suppressed. This saves time so that you can quickly simulate design alternatives without having to physically delete or recreate objects in your motion simulation. If you then unsuppress one of the dependent objects, that object's parent object will also be unsuppressed.

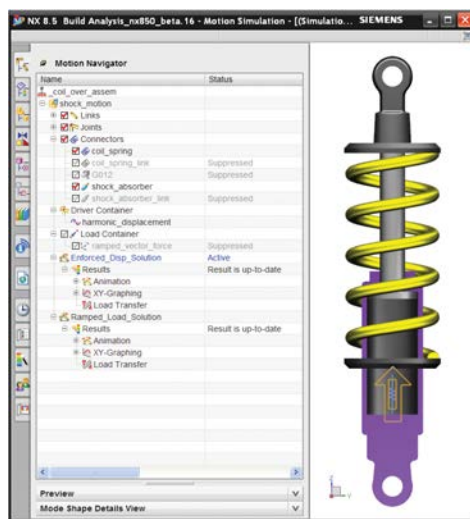

Suppress motion objects from motion simulation model for quick debugging or evaluation of alternative ideas.

NX 8.5 for manufacturing productivity

NX 8.5 boosts part manufacturing productivity in the machinery, turbomachinery, aerospace, medical, and mold and die industries. Save time programming and machining parts with new machining operations, more tool path control and easier ways to automate programming. Close the quality loop by creating CMM inspection programs and analyzing results all directly within NX. Save on tooling costs and use the right data from NC programming through to machining with new tool library and CAM data management capabilities.

Machining productivity

NX CAM delivers the next level of NC programming productivity with specialized industry-specific capabilities.

NX CAM for machinery Volume-based 2.5D milling provides a very fast and intuitive method of programming prismatic parts. Simply select faces such as walls and floors within the 3D part model to define the machined volumes. An instant visual preview provides fast and easy validation of the planned machining operation. Programming can be 5 to 10 times faster. The system continuously keeps track of uncut material and minimizes air-cutting, reducing machining time up to 10 percent.

Multi-stage machining processes also track the in-process workpiece for greater efficiency. Updated blank models are automatically maintained for each station.

Advances in feature-based machining automate the sorting of machining operations across multiple setups for faster, easier programming.

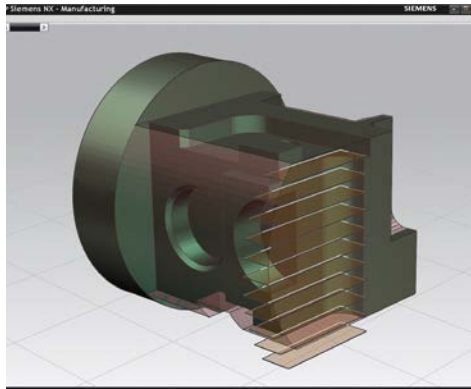

Volume-based 2.5D milling speeds programming for machinery.

Turbomachinery milling New roughing operation options improve machining efficiency for turbines and multibladed parts. By adding depths to slotting motions, roughing operations can be assigned higher feed rates or deeper depths. Additional finishing options provide swarf (flank) milling and also allow

incremental rough/finish operations between thin blades to maintain rigidity and improve finish quality.

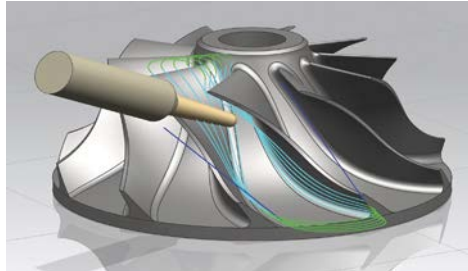

New finish patterns allow incremental finishing for thin blades.

Aerospace and medical Swarf or flank milling with the new contact point control reduces passes and produces a better surface finish on complex parts that require 5-axis strategies that cut with the side of the endmill. By positioning the tool tip past the contact point, more material can be removed per pass leaving smaller cusps and extending tool life.

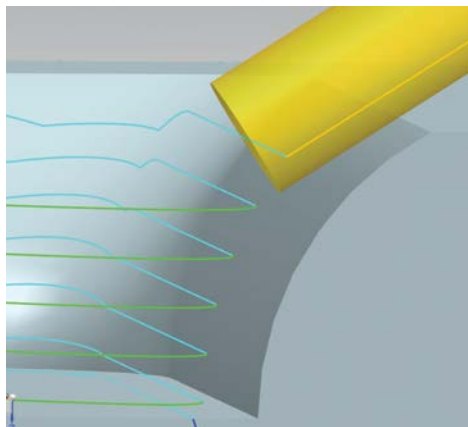

5-axis flank milling options make smaller cusps.

Mold and die Valley restmilling is enhanced with new hybrid Z-level and projected patterns that identify, sort and prioritize the valleys to find the best cutting motions. By combining steep and nonsteep cutting approaches into a single pattern, you can easily clean out valleys with various orientations and achieve a smooth finish.

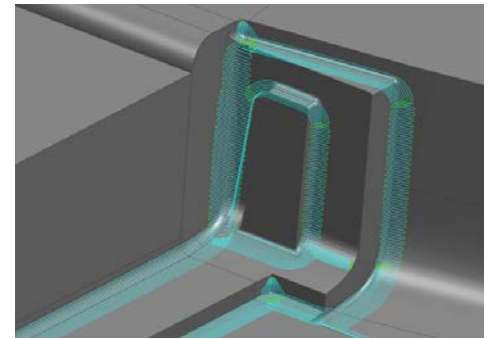

Cutting directions are optimized for the best finish.

Tool library The enhanced NX CAM tooling library supports a broader definition of tools that includes tooling devices and holders. It also includes context information for faster machine simulation setups such as pocket assignments, mounting points and visual previews.

The new Manufacturing Resource Library (MRL) is used to manage tooling vendor catalogs and preferred tool assemblies, as well as your custom resources. The MRL stores and classifies its content in

Teamcenter, with a full range of search functions and graphical displays so you can easily find and access your tools. From NX CAM, you can search the library, find the tools you need, and pull in accurate 3D models of the selected cutting tools right into your CAM programming session.

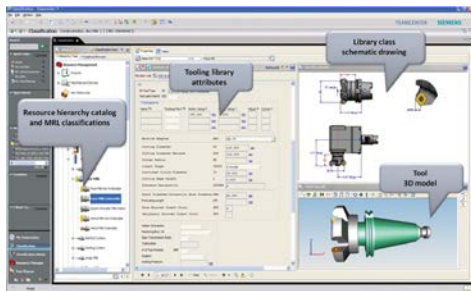

Powerful new tool library capabilities available for NX 8.5.

CMM inspection programming and results analysis

Maximize the efficiency of your complete quality inspection process with the enhanced offline programming and new inspection results analysis capabilities in NX.

NX CMM data analysis Users can quickly see and evaluate their “as-built” measurements in the graphical NX environment, right next to the “as designed” models that drive the CMM inspection programs. Putting the measurement results into context helps manufacturers find the most effective approaches to achieve quality improvements.

CMM measurements are read back into NX as .mea or .dml files. They are compared to the measured datums, including the associated tolerances according to ANSI Y14.5, ASME Y14.5 or ISO 1011 standards. Measurements are displayed in the operation navigator as a list and linked to the graphical display for each measurement. Best-fit analysis and verification help illuminate the possible causes of tolerance failure and assist in decision making that will improve component quality.

NX CMM inspection programming CMM inspection programmers work directly in the NX 3D environment and use the PMI information, GD&T applied right to the solid, to generate programs quickly. NX 8.5 delivers time saving updates, such as new transitions methods that find key interferences and automatically resolve them. Scans are previewed with probe orientations to make sure the desired results are achieved. More complex scans can span multiple features.

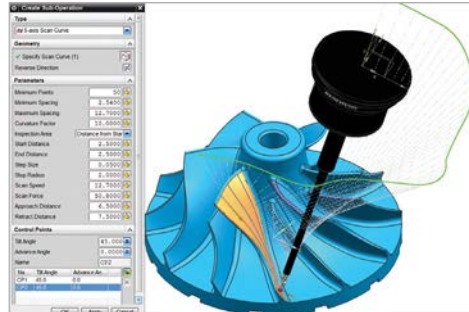

5 axis scanning with NX 8.5 CMM Inspection Programming.

Data management

CAM Data Management helps to eliminate the delays and costs that come with bad data. The introduction of the Manufacturing Resource Library (MRL) and the Manufacturing Resource Library Connect for NX products make big advances in building and making available complete and accurate tool data.

Manufacturing Resource Library The new Manufacturing Resource Library (MRL) is used to manage tooling vendor catalogs and preferred tool assemblies, as well as your custom resources. The MRL stores and classifies its content in Teamcenter, Siemens PLM Software’s comprehensive system for managing product lifecycle management (PLM) data and processes, with a full range of search functions and graphical displays so you can easily find and access your tools. From NX CAM, you can search the library, find the tools you need, and pull accurate 3D models of the selected cutting tools right into your CAM programming session.

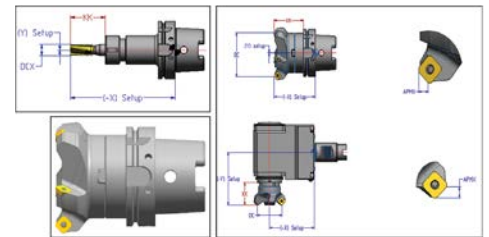

Tool definitions include solid models ready for NC simulation.

Manufacturing Resource Library

Connect for NX A lightweight web-based interface connects even disconnected NC programmers to the rich tooling data of the MRL. NC programmers can browse, search and select tooling assemblies from the MRL. Of course, this includes the solid assembly representations that then further improve the simulation of the NC operation.

Shop Floor Connect for Teamcenter Shop Floor Connect for Teamcenter delivers CNC program files directly to machine controllers. More than just a traditional DNC system, the connection to the centralized Teamcenter database ensures that manufacturing data is secure and the manufacturing plan-to-production process is controlled. It avoids data duplication and manages revisions to make sure the correct manufacturing data is used on the shop floor.

With Shop Floor Connect, machine operators can directly access production released data. Using job numbers or work package identifiers, operators can locate the correct data files needed for production, including CNC programs, tool lists, setup sheets and drawings. When CNC programs are created, modified or optimized by the production team, they can be saved and maintained as new data or revisions to existing data.



Shop floor personnel can directly access the data they need.

Contact
 Siemens Industry Software
 Americas +1 800 498 5351
 Europe +44 (0) 1276 702000
 Asia-Pacific +852 2230 3333

www.siemens.com/nx

© 2012 Siemens Product Lifecycle Management Software Inc. All rights reserved. Siemens and the Siemens logo are registered trademarks of Siemens AG. D-Cubed, Femap, Geolus, GO PLM, I-deas, Insight, JT, NX, Parasolid, Solid Edge, Teamcenter, Tecnomatix and Velocity Series are trademarks or registered trademarks of Siemens Product Lifecycle Management Software Inc. or its subsidiaries in the United States and in other countries. Nastran is a registered trademark of the National Aeronautics and Space Administration. All other logos, trademarks, registered trademarks or service marks used herein are the property of their respective holders. X18 31071 8/12 B